



## Polypipe Civils Ltd

Union Works  
 Bishop Meadow Road  
 Loughborough  
 Leicestershire LE11 5RE  
 Tel: 01509 615100 Fax: 01509 265945  
 e-mail: [civils\\_sales@polypipe.com](mailto:civils_sales@polypipe.com)  
 website: [www.polypipecivils.co.uk](http://www.polypipecivils.co.uk)

**Agrément  
 Certificate  
 No 06/4297**

Designated by Government  
 to issue  
 European Technical  
 Approvals

## POLYSTORM STORMWATER MANAGEMENT SYSTEM

Système de gestion des eaux d'orages  
 Verwaltungssystem von gewitterwasser

## Product



• THIS CERTIFICATE RELATES TO THE POLYSTORM STORMWATER MANAGEMENT SYSTEM, AS DESCRIBED IN THE ACCOMPANYING DETAIL SHEET.

- The system can be used either for stormwater storage or as a soakaway to control stormwater run-off from impermeable surfaces.
- This system does not cover the collection of the stormwater. For information relating to this, the Certificate holder should be contacted.

These Front Sheets must be read in conjunction with the accompanying Detail Sheet, which provides information specific to this system.

## Regulations — Detail Sheet 1

### 1 The Building Regulations 2000 (as amended) (England and Wales)



The Secretary of State has agreed with the British Board of Agrément that aspects of performance to be used by the BBA in assessing the compliance of soakaways and stormwater storage structures constructed from polypropylene units with the Building Regulations. In the opinion of the BBA, soakaways and stormwater storage structures constructed from the Polystorm Stormwater Management System, if used in accordance with the provisions of this Certificate, will meet or contribute to meeting the relevant requirements.

Requirement: H3(3)

Rainwater drainage

Comment:

The system can be used in a construction to meet this Requirement. See the tinted area in *Hydraulic design* section of the accompanying Detail Sheet.

Requirement: Regulation 7

Materials and workmanship

Comment:

The system components are acceptable. See the tinted area in the *Durability* section of the accompanying Detail Sheet.

# Electronic Copy

## 2 The Building (Scotland) Regulations 2004



In the opinion of the BBA, soakaways and stormwater storage structures constructed from the Polystorm Stormwater Management System, if used in accordance with the provisions of this Certificate, will satisfy or contribute to satisfying the various Regulations and related Mandatory Standards as listed below.

Regulation:	8	Fitness and durability of materials and workmanship
Regulation:	8(1)	Fitness and durability of materials and workmanship
Comment:		The system can contribute to satisfying this Regulation. See the tinted area in the <i>Durability</i> section and the <i>Installation</i> part of the accompanying Detail Sheet.
Regulation:	9	Building standards — construction
Standard:	3.6	Surface water drainage
Comment:		The system can contribute to a construction satisfying this Standard, with reference to clauses 3.6.3 <sup>(1)(2)</sup> , 3.6.4 <sup>(1)(2)</sup> , 3.6.5 <sup>(1)</sup> and 3.6.5 <sup>(2)</sup> . See the tinted area in <i>Hydraulic design</i> section of the accompanying Detail Sheet. (1) Technical Handbook (Domestic). (2) Technical Handbook (Non-Domestic).

## 3 The Building Regulations (Northern Ireland) 2000



In the opinion of the BBA, soakaways and stormwater storage structures constructed from the Polystorm Stormwater Management System, if used in accordance with the provisions of this Certificate, will satisfy or contribute to satisfying the various Building Regulations as listed below.

Regulation:	B2	Fitness of materials and workmanship
Comment:		The system components are acceptable. See the tinted area in the <i>Durability</i> section of the accompanying Detail Sheet.
Regulation:	N5	Rain-water drainage
Comment:		The system can be used in a construction to satisfy this Regulation. See the tinted area in <i>Hydraulic design</i> section of the accompanying Detail Sheet.

## 4 Construction (Design and Management) Regulations 1994 (as amended)

### Construction (Design and Management) Regulations (Northern Ireland) 1995 (as amended)

Information in this Certificate may assist the client, planning supervisor, designer and contractors to address their obligations under these Regulations.

See sections: 2 *Delivery and site handling* (2.1 and 2.3) and 12 *Procedure* (12.1 and 12.10) of the accompanying Detail Sheet.

## Conditions of Certification

### 5 Conditions

5.1 This Certificate:

- (a) relates only to the product that is named, described, installed, used and maintained as set out in this Certificate;
- (b) is granted only to the company, firm or person identified on the front cover — no other company, firm or person may hold or claim any entitlement to this Certificate;
- (c) is valid only within the UK;
- (d) has to be read, considered and used as a whole document — it may be misleading and will be incomplete to be selective;
- (e) is copyright of the BBA;
- (f) is subject to English law.

5.2 References in this Certificate to any Act of Parliament, Regulation made thereunder, Directive or Regulation of the European Union, Statutory Instrument, Code of Practice, British Standard, manufacturers' instructions or similar publication, are references to such publication in the form in which it was current at the date of this Certificate.

5.3 This Certificate will remain valid for an unlimited period provided that the product and the manufacture and/or fabrication including all related and relevant processes thereof:

- (a) are maintained at or above the levels which have been assessed and found to be satisfactory by the BBA;

(b) continue to be checked as and when deemed appropriate by the BBA under arrangements that it will determine; and

(c) are reviewed by the BBA as and when it considers appropriate.

5.4 In granting this Certificate, the BBA is not responsible for:

- (a) the presence or absence of any patent or similar rights subsisting in the product or any other product;
- (b) the right of the Certificate holder to market, supply, install or maintain the product; and
- (c) the nature or standard of individual installations of the product or any maintenance thereto, including methods and workmanship.

5.5 Any recommendations relating to the use or installation of this product which are contained or referred to in this Certificate are the minimum standards required to be met when the product is used. They do not purport in any way to restate the requirements of the Health & Safety at Work etc Act 1974, or of any other statutory, common law or other duty which may exist at the date of this Certificate or in the future; nor is conformity with such recommendations to be taken as satisfying the requirements of the 1974 Act or of any present or future statutory, common law or other duty of care. In granting this Certificate, the BBA does not accept responsibility to any person or body for any loss or damage, including personal injury, arising as a direct or indirect result of the installation and use of this product.



In the opinion of the British Board of Agrément, the Polystorm Stormwater Management System is fit for its intended use provided it is installed, used and maintained as set out in this Certificate. Certificate No 06/4297 is accordingly awarded to Polypipe Civils Ltd.

On behalf of the British Board of Agrément

Date of issue: 1st March 2006

A handwritten signature in black ink, appearing to read 'G. A. Cooper', is written over a light grey background.

Chief Executive

# Electronic Copy

---

**British Board of Agrément**

P O Box No 195, Bucknalls Lane  
Garston, Watford, Herts WD25 9BA  
Fax: 01923 665301

©2006

e-mail: [mail@bba.star.co.uk](mailto:mail@bba.star.co.uk)  
website: [www.bbacerts.co.uk](http://www.bbacerts.co.uk)



For technical or additional information,  
contact the Certificate holder (see  
front page).  
For information about the Agrément  
Certificate, including validity and  
scope, tel: Hotline 01923 665400,  
or check the BBA website.



Polypipe Civils Ltd

Certificate No 06/4297

**DETAIL SHEET 2**

**POLYSTORM 40 TONNE UNITS**

## Product

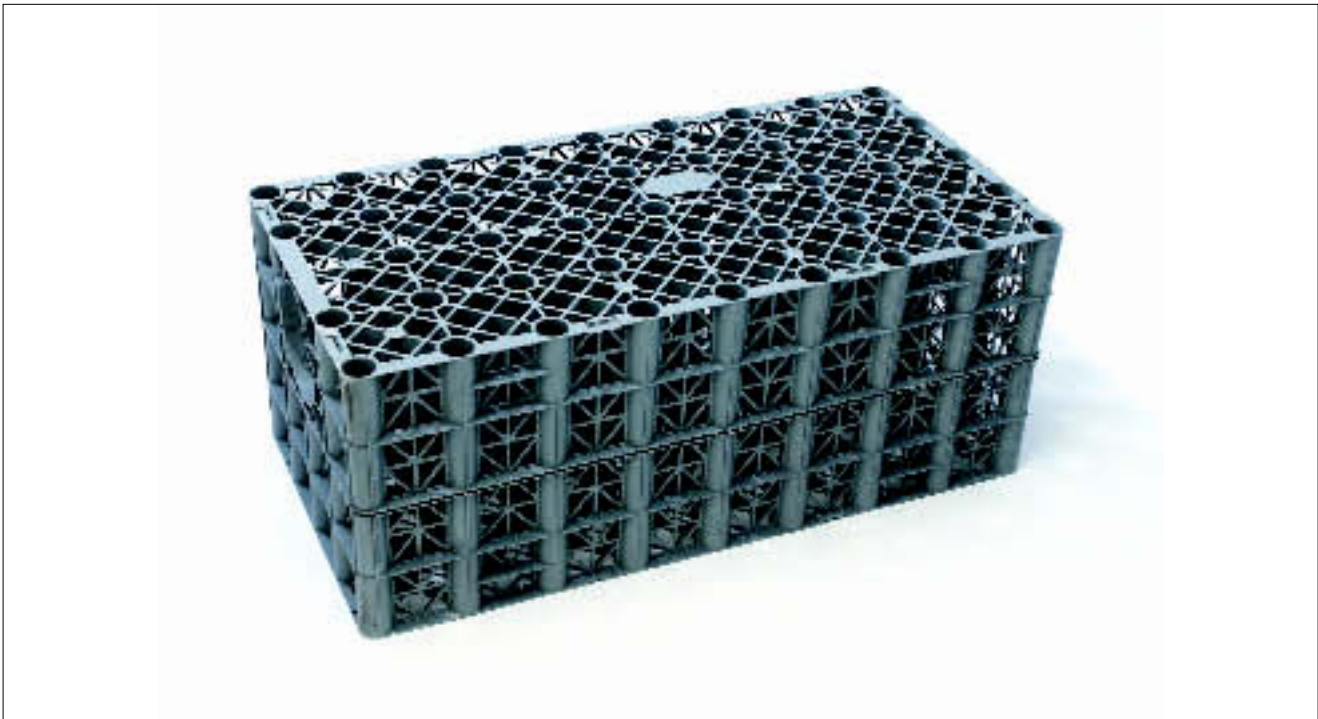

- THIS DETAIL SHEET RELATES TO POLYSTORM 40 TONNE UNITS.
- The product can be used for stormwater storage or as a soakaway to control stormwater run-off from impermeable surfaces.

This Detail Sheet must be read in conjunction with the Front Sheets, which give the product's position regarding the national Building Regulations and Conditions of Certification.

## Technical Specification

### 1 Description

1.1 Polystorm 40 Tonne Units are modular units (see Table 1), used in conjunction with shear connectors and clips. The units are manufactured from light grey polypropylene. All other items are manufactured from black polypropylene (see Figure 1).

Table 1 Characteristics of modular unit

Element (unit)	Value
Unit dimensions (nom) (mm)	1000 x 500 x 400
Unit volume (nom) (m <sup>3</sup> )	0.20
Storage volume (nom) (m <sup>3</sup> )	0.19
Porosity (void ratio) (%)	95
Ultimate compressive strength at yield (kNm <sup>-2</sup> )	
vertical loading on top face	440
lateral loading on side face	63
Short-term deflection (mm per kNm <sup>-2</sup> ) <sup>(1)</sup>	
vertical loading on top side face	1 per 83
lateral loading on side face	1 per 4.2
Estimated long-term deflection <sup>(2)</sup> (Ln) <sup>(3)</sup>	0.2794

(1) Applied load.

(2) At up to 10 years at 20°C at 10 kN load.

(3) Time in days.

Figure 1 Components

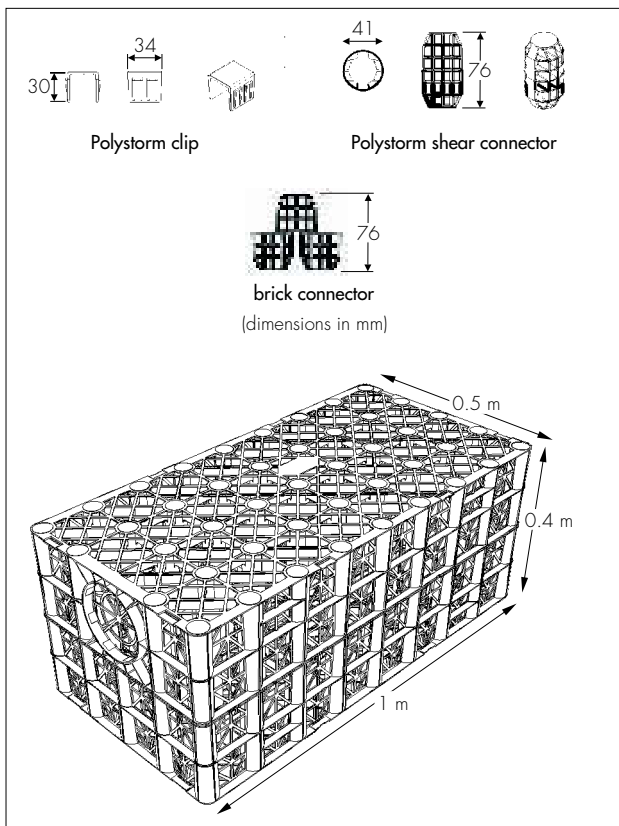

1.2 The units control stormwater run-off from impermeable surfaces by either:

- infiltration — soakaways to infiltrate stormwater back into the ground, or
- attenuation — temporary storage for excess flows and limiting outflow to streams and rivers.

1.3 The polypropylene modular units have preformed sockets to enable connection with 160 mm diameter pipework (to BS EN 1401-1 : 1998), or alternatively, connection to 150 mm Ridgidrain 110 mm or 100 mm pipework is possible using suitable adaptors. Adaptors and connecting pipework for use with this system are not covered by the scope of this Certificate. Geotextiles and geomembranes for use with this system are not covered by the scope of this Certificate. Information on the required specification of the geotextile and/or geomembrane can be obtained from the Certificate holder.

1.4 Each assembly is wrapped in either a permeable geotextile when used for infiltration or an impermeable geomembrane when used for storage (attenuation).

1.5 Adequate venting must be provided to the Polystorm structure using an air vent. One 110 mm diameter air vent is required per 7500 m<sup>2</sup> of impermeable catchment area to be drained. Air vent connections and pipework for use with this system are outside the scope of this Certificate.

## 2 Delivery and site handling

2.1 The units are supplied to site in packs of 12 or 15 units secured to a wooden pallet. Each pack

carries a label bearing the product name, quantity, operator initials and pallet number.

2.2 Clips, shear connectors and brick bond connectors are packed in sealed polythene bags of 60, 30 and 30 respectively.

2.3 The unit packs should be carefully placed on level ground and should not be stacked on site. Loose individual units should not be stored more than two units high.

2.4 The units contain an inhibitor to resist the effects of ultraviolet light for up to six months. However, prolonged storage in direct sunlight should be avoided.

2.5 The units should not be stored near fuel bowsers, fuel tanks or other solvents.

2.6 The units are resistant to damage likely to be caused during normal handling. They should be stored in locations where impacts from vehicles and other construction plant will be avoided.

## Design Data

### 3 General

3.1 Polystorm 40 Tonne Units design must be in accordance with the Certificate holder's installation instructions. Guidance on the application of sustainable drainage systems (SUDS) for new developments, such as the Polystorm Stormwater Management System, can also be found in the Planning Policy Guidance PPG25 *Development and Flood Risk*.

3.2 The units are suitable for the control of stormwater run-off from impermeable surfaces. It can be utilised in two main ways (see Figure 2):

- infiltration — water is collected in the units during rainfall and allowed to drain away by soaking into the surrounding ground over a substantial period of time after the rain has stopped
- attenuation — water is collected in the units during rainfall and released at a reduced flow rate through a flow control device, into an appropriate outfall. This reduces peak flows in the watercourse and, therefore, minimises the risk of flooding.

3.3 Design of the appropriate units for a specific project must always be preceded by a detailed audit of the proposed site to establish:

- existing factors and considerations applicable to the site
- predicted factors relating to the site's use following the planned development, and the parameters within which the installation is required to function
- the type of function of application suggested by this audit.

## 4 Hydraulic design

Figure 2 Sustainable drainage system selection and design

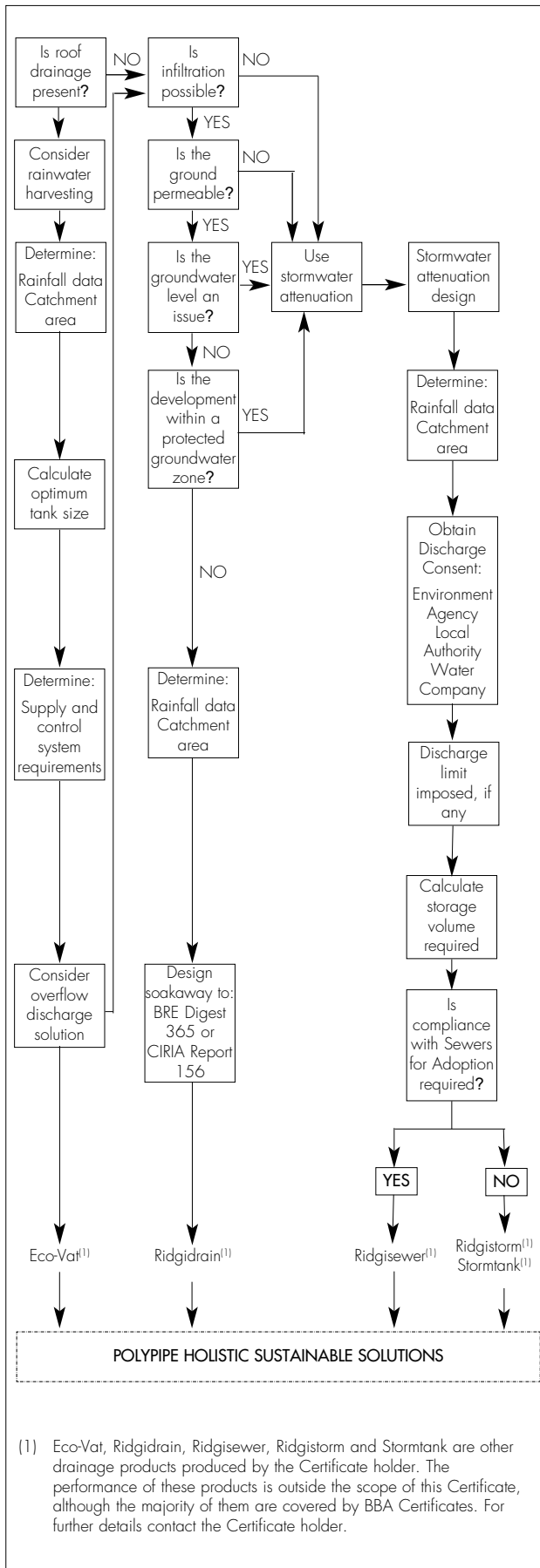

3.4 Once the project criteria have been established from the site audit, there are two main parts to the design procedure: hydraulic design and structural design.

### Infiltration

#### Calculation principles

4.1 There are two approaches, either of which may be adopted: the Construction Industry Research and Information Association (CIRIA) Report 156 *Infiltration Drainage — Manual of Good Practice* or BRE Digest 365 *Soakaway Design*.

4.2 A simplified approximate approach can be used on a very small site (ie a single-house development) where detailed site infiltration rate information may not be required nor available (see Table 2). Approved Document H allows a storage volume equal to the area to be drained multiplied by 10 mm, for areas up to 25 m<sup>2</sup>. Beyond this size, design should be carried out in accordance with BS EN 752-4 : 1998 or BRE Digest 365. BS EN 752-4 : 1998 suggests a storage volume equal to 20 mm multiplied by the area to be drained.

Table 2 Simplified soakaway design for single house development<sup>(1)</sup>

Number of units	Storage volume (m <sup>3</sup> )	Max area to be drained (m <sup>2</sup> )
1	0.19	19.0 <sup>(2)</sup>
2	0.38	25.0 <sup>(2)</sup>
3	0.57	28.5 <sup>(3)</sup>
4	0.76	38.0 <sup>(3)</sup>
5	0.95	47.5 <sup>(3)</sup>
6	1.14	57.0 <sup>(3)</sup>

(1) When doubt exists over suitability of ground for infiltration permeability figures should be derived by test (see BRE Digest 365).

(2) In accordance with Approved Document H.

(3) In accordance with BS EN 752-4 : 1998, Clause NG 2.4.

4.3 When the BRE or CIRIA approach is used, the design volumes and areas for trench or cuboid type installations can be found from Tables 3 and 4.

Table 3 Volumetric data per linear metre for a one unit (0.5 m) wide trench configuration

Number of units high	Volume (m <sup>3</sup> )	Side area (m <sup>2</sup> )	Base area (m <sup>2</sup> )
1	0.19	0.8	0.5
2	0.38	1.6	0.5
3	0.57	2.4	0.5

Table 4 Volumetric data for 3D usage two units high

Units long (1 m side)	2 wide (0.5 m side)			4 wide (0.5 m side)			8 wide (0.5 m side)		
	vol m <sup>3</sup>	side m <sup>2</sup>	base m <sup>2</sup>	vol m <sup>3</sup>	side m <sup>2</sup>	base m <sup>2</sup>	vol m <sup>3</sup>	side m <sup>2</sup>	base m <sup>2</sup>
1	0.76	3.2	1.0	1.52	4.8	2.0	3.04	8.0	4.0
2	1.52	4.8	2.0	3.04	6.4	4.0	6.08	9.6	8.0
4	3.04	8.0	4.0	6.08	9.6	8.0	12.16	12.8	16.0
8	6.08	14.4	8.0	12.16	16.0	16.0	24.32	19.2	32.0
10	7.60	17.6	10.0	15.20	19.2	20.0	30.40	22.4	40.0
100	76.00	161.6	100.0	152.00	163.2	200.0	304.00	166.4	400.0

4.4 For calculations, the size and volume of the units are given in Table 1. The total areas of the base and sides are required as water is absorbed through the geotextile soil interface. Storage volume is 95% of the total volume. As an example, using Table 4, for a typical linear trench 40 m long and two units deep, the volume is  $0.38 \times 40 = 15.2 \text{ m}^3$  and the side area  $1.6 \times 40 = 64 \text{ m}^2$ .

## Attenuation

### Calculation principles

4.5 The anticipated run-off volume (A) from the site must be estimated. The most commonly-used method for evaluating storm rainfall events in the UK is the Wallingford Procedure by which the total rainfall level of storms over defined time periods ranging from five minutes up to 48 hours are assessed. The depth of water (mm) found can be multiplied by the catchment area to assess the size of attenuation systems and is traditionally based upon a storm duration and of a return period appropriate for the catchment. The allowable discharge rate from the site to an appropriate outfall is established but will normally be set by the Environment Agency or Planning Authorities. The outflow volume (B) to be discharged at this rate over the two-hour period is calculated and subtracted from the run-off volume (A-B). This defines the excess volume (C) to be stored in Polystorm units constructed as an underground tank. The number of units needed to contain this excess is calculated on the basis that the storage volume is equal to 95% of the total volume of the tank.

## Connections

4.6 Connection is made to the units using a preformed socket and adaptor. These items are not covered by the scope of this Certificate.

## Manifold design



4.7 The units are manufactured to allow a connection to be easily formed by insertion of 160 mm diameter BS EN 1401-1 : 1998 pipes into the convenient knock-out incorporated in each cell. The capacity of a 160 mm pipe is limited and may be insufficient for the anticipated design flow. The flow may be split amongst a number of 160 mm pipes connected to a manifold to provide increased hydraulic capacity (see Figure 3). The system designer should ensure the pipework connecting the Polystorm units to the drainage system has sufficient capacity to cope with the design flow.

## Flow control

4.8 The outflow from the tank must be controlled to comply with the discharge rate consent of the site. The main methods to achieve outflow control are: orifice plate, vortex control or small pipe. Comparative features and benefits of these various control flow devices should be considered prior to selection. These devices are not within the scope of this Certificate.

## Outflow positioning and head calculations

4.9 The invert level of the outflow pipe should be flush with the bottom of the lowest unit to allow the tank to drain. As the tank fills, a depth of water develops on the upstream side of the outflow control. For a tank with two layers of units, this depth is 0.8 m when the units are full, creating a driving head to push the flow through the control device. For design purposes, the head used in calculations is taken as that at the invert line of the outflow device.

Figure 3 Typical manifold design

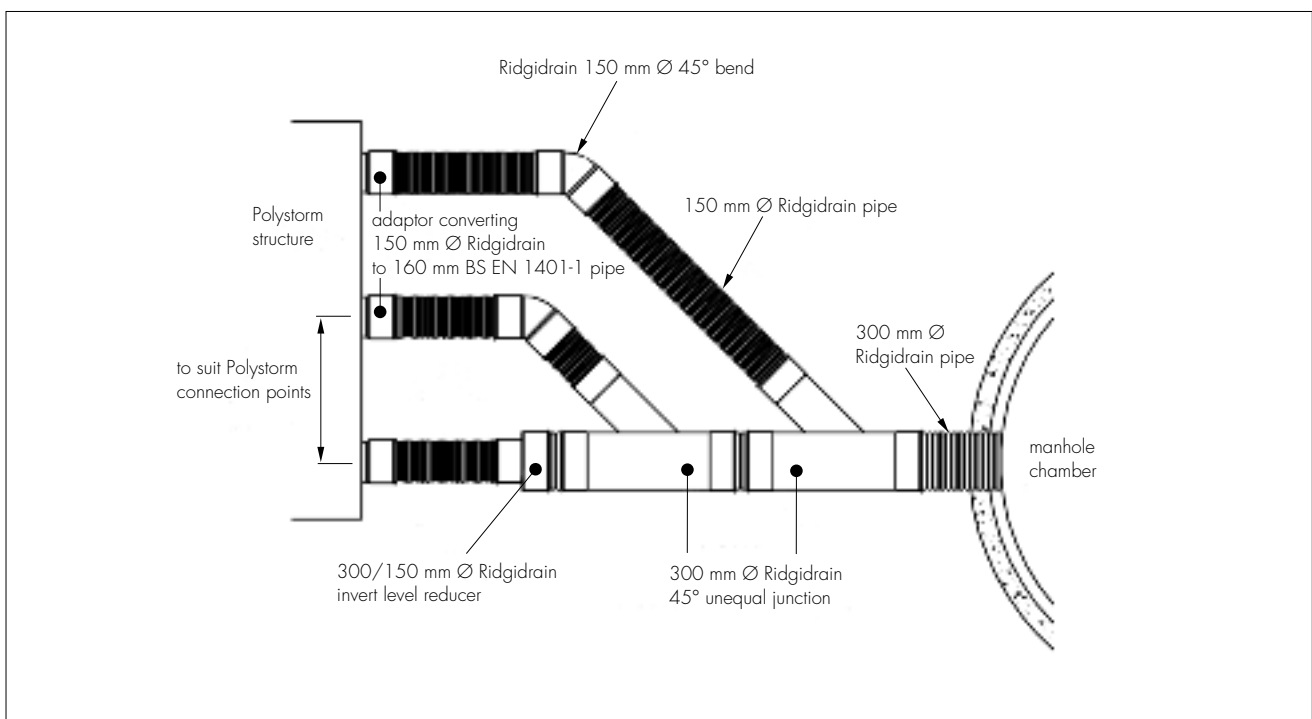

## 5 Structural design

5.1 The units can be placed under a wide variety of landscaped or lightly-trafficked areas. Design procedures for heavily-trafficked applications are not within the scope of this Certificate. If the proposed application of the system is in areas subject to high-intensity traffic, commercial vehicles or other heavy loads, advice should be sought from the Certificate holder.

5.2 Short-term loading design parameters for the Polystorm units have been derived from independent test data (see Table 5). The short- and long-term deflection is given in Table 1.

**Table 5** Loading design parameters for Polystorm units<sup>(1)</sup>

	Vertical loading on top face	Lateral loading on side face
Short-term compressive strength at yield (kNm <sup>-2</sup> )	440	63

(1) A partial factor safety for materials,  $F_{m'}$ , of 2.75 for ultimate limit state and 1.5 for serviceability limit state, should be applied to these values for a design life of 20 years.

5.3 Typical creep results (see Figure 4) enable a long-term rate of deflection to be determined and long-term deformations for periods up to 20 years estimated. In locations where settlement is not of concern, then designs up to 50 years can be undertaken.

**Figure 4** Typical creep test results

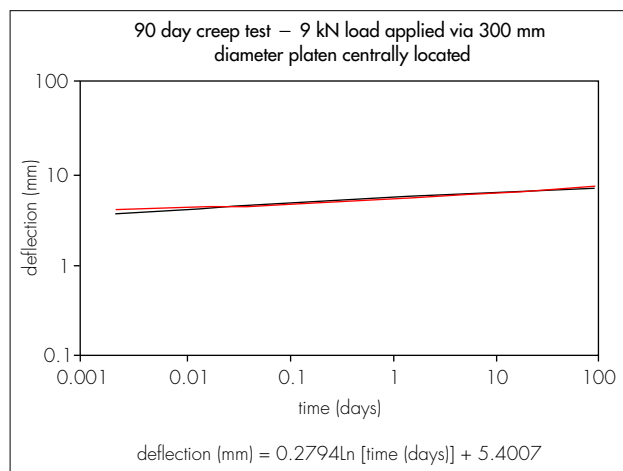

5.4 For small-scale application such as soakaways for individual house roof drainage, the system is typically located below a garden a minimum of 5 m from the building (see Table 6). In this case there are no traffic loads.

**Table 6** Design criteria for use of Polystorm system as soakaway for individual house<sup>(1)</sup>

Maximum depth to base of units	3.0 m
Minimum cover depth	0.5 m

(1) The following assumptions apply:

- minimum angle of shearing resistance for surrounding soil 29°. To be confirmed by site survey.
- groundwater should be at least one metre below the base of the Polystorm units.

5.5 The units used for large-scale storage or infiltration must be designed to carry all loads that will be applied, including dead and imposed loads. Design parameters and estimated loads should be used to determine the maximum depth of installation and the maximum and minimum cover depths.

5.6 The criteria provided in Tables 7 and 8 can be used to design the units for installation below lightly- and non-trafficked areas. These design tables are only applicable in temperate climate conditions such as the UK. The following partial safety factors for loads have been applied:

- ultimate limit state — vertical dead load,  $F_{dl}$ , 1.40, earth pressure (horizontal) dead load,  $F_{ep}$ , 1.40, imposed live load,  $F_{ll}$ , 1.60
- serviceability limit state — vertical dead load,  $F_{dl}$ , 1.00, earth pressure (horizontal) dead load,  $F_{ep}$ , 1.00, imposed live load,  $F_{ll}$ , 1.00.

5.7 Partial factors of safety for materials,  $F_{m'}$ , of 2.75 for ultimate limit state and 1.5 for serviceability limit state have been applied.

5.8 The system can be used for areas where greater loads are anticipated but these applications are outside the scope of this Certificate and specific advice should be sought from the Certificate holder.

5.9 Ensure that the ground-bearing capacity at the formation level is sufficient for the proposed operational loads. In areas of weak or compressible soils advice should be sought from a geotechnical engineer.

**Table 7** Maximum installation depths (to base of units)

Soil description	Typical angle of friction ( $\phi$ )	Maximum installation depth (from invert of structure) (m)			
		No groundwater present		Groundwater level 1.0 m below ground level (attenuation structure)	
		Trafficked (cars only)	Non-trafficked	Trafficked (cars only)	Non-trafficked
Over consolidated stiff clay	24°	2.1	2.2	1.5	1.6
Silty sandy clay	26°	2.3	2.4	1.5	1.6
Loose sand and gravel	30°	2.5	2.7	1.6	1.7
Medium dense sand and gravel	33°	3.0	3.1	1.7	1.7
Dense sand and gravel	38°	3.7	3.8	1.8	1.8

**Table 8** Minimum cover depths over top of Polystorm units

Live load conditions	Field	Light Trafficking	
		Car park with vehicle mass <2500 kg	Car park with occasional vehicle mass >2500 kg
Minimum cover depth required (m)	0.50	0.60	0.80

5.10 Care should be taken when the units are used for infiltration below trafficked areas and close to structures. It is important to ensure that the infiltrating water will not soften the soils or cause loss of fines and settlement.

5.11 When the units are wrapped in geomembrane and placed below the groundwater table, flotation may occur. To prevent this the weight of the soil over the top of the units must be greater than the uplift force caused by the unit's buoyancy in the water. This can be achieved with most types of fill if the depth of cover fill is equal to, or greater than, the depth of penetration of the units below groundwater level.

## 6 Geotextiles and geomembranes

### Attenuation

6.1 The units require a sealed geomembrane wrapping to create an attenuation storage tank and prevent:

- the release of surface water into the surrounding ground; and
- inflow of groundwater that may overload downstream systems and contain pollutants on contaminated sites.

6.2 Site conditions may require the use of a thick, protective geotextile to prevent puncture or excessive strain in the geomembrane, on which further advice should be sought from the geomembrane manufacturer.

6.3 Selection of an appropriate geomembrane requires careful consideration (see section 10.6).

### Infiltration

6.4 The units require a geotextile wrapping when used as an infiltration device to prevent:

- silt that may be contained in the surface water runoff from contaminating the surrounding soil, in addition to reducing its permeability; and
- surrounding soil from entering the units.

6.5 Selection of an appropriate geotextile requires careful consideration (see section 6.6).

### Specification of geosynthetic

6.6 Careful consideration should be given to the selection of an appropriate geosynthetic. A recognised design methodology is to follow these steps:

- (1) define the application filter requirements — retention (attenuation storage) or permeability (soakaway)
- (2) define boundary conditions — site investigation to establish in-situ soil parameters, enabling lateral earth pressures and water flow conditions to be calculated
- (3) determine soil retention requirements — using the in-situ soil parameters, determine if additional bed and surround measures should be specified

- (4) determine geosynthetic permeability requirements — the breakthrough head should be considered in addition to water flow rates
- (5) determine anti-clogging requirements (infiltration only) — ensure that the porosity of the geotextile, in conjunction with the specified bed and surround is sufficient to prevent the geotextile from prematurely clogging
- (6) determine survivability requirements — the geosynthetic should be sufficiently robust to survive installation activities
- (7) determine durability requirements — consideration should be given as to whether the geosynthetic will be subjected to a significant chemical exposure, either present in the ground or rainwater runoff
- (8) miscellaneous design considerations:
  - intrusion of geosynthetic into drainage layer
  - biological and bio-chemical clogging factors
  - safety factors.

6.7 All joints should be sealed, using proprietary techniques recommended by the manufacturer. Please refer to CIRIA SP 124 : 1996 — *Barriers, liners and cover systems for containment and control of land contamination*, for advice on seam testing procedures.

6.8 The designer/installer should confirm with the geosynthetic manufacturer that the specification of the proposed material is suitable for the application and site conditions by following the design methodology (see section 6.6). Typical geosynthetic specifications are given in Tables 9 and 10.

Table 9 Typical specification for a polypropylene geomembrane

Impermeable geomembrane		
<b>Physical properties</b>		
Thickness	Min 1.0 mm	ASTM D 5199
Density	900 kgm <sup>-3</sup>	ASTM D 1505
<b>Mechanical properties</b>		
Tensile strength, at yield	Min 1600 kNm <sup>-2</sup>	ASTM D 4885
Elongation at break	>500%	ASTM D 4885
Puncture resistance	Min 170 N	ASTM D 4833
Tear resistance	Min 67 N	ASTM D 1004 Die C
Impact resistance	Min 15 joules	ASTM D 3998 mod
Stress crack resistance	Min 200 h	ASTM D 5397 (SP-NCTI)
Permeability coefficient	Max 2.0 x 10 <sup>-12</sup>	ASTM D 4491
pH	Resistant to all naturally occurring soil acids and alkalis	
Chemical/biological	Resistant to all substances found to naturally occur in soils and rainwater. Detailed information would need to be provided to geosynthetic manufacturer in instances of contaminated land	

Figure 5 Typical Polystorm arrangement including ventilation pipe

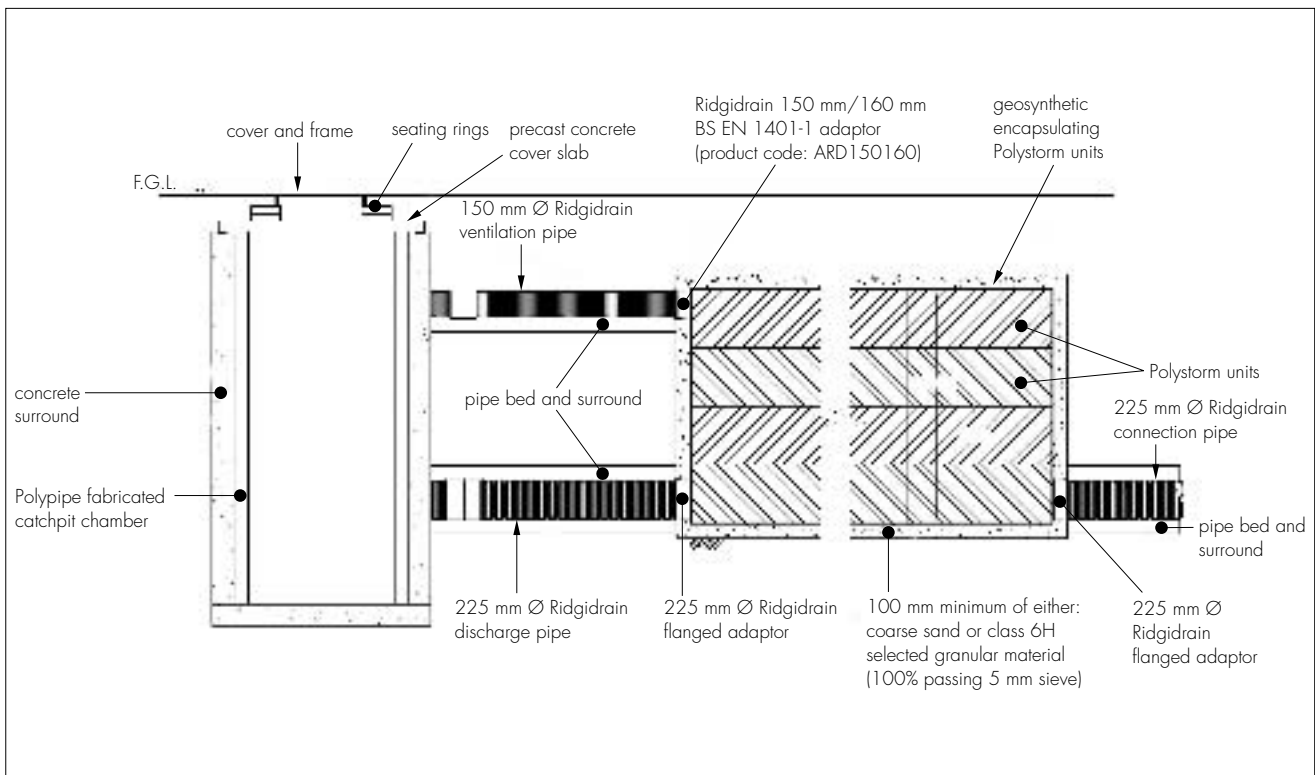

Table 10 Typical specification for a geotextile

Permeable geotextile		
<b>Physical properties</b>		
Material	Typically polypropylene/polyethylene	
Mass	Min 1.25 gm <sup>-2</sup>	EN 965
<b>Mechanical properties</b>		
CBR puncture resistance	Min 1500 N	EN ISO 12236
Peak tensile strength	Min 8 kNm <sup>2</sup>	EN ISO 10319
<b>Hydraulic properties</b>		
Water flow rate normal to plane	Min 100 ls <sup>-1</sup> m <sup>-1</sup> (at 50 mm head)	EN ISO 11058
Pore size O <sub>90</sub>	Typical 100 µm	EN ISO 12956
pH	Resistant to all naturally occurring soil acids and alkalis	
Chemical/biological resistance	Resistant to all substances found to naturally occur in soils and rainwater. Detailed information would need to be provided to geosynthetic manufacturer in instances of contaminated land	

## 7 Venting

Adequate venting must be provided to the structure. One 110 mm diameter air vent is required per 7500 m<sup>2</sup> of impermeable catchment area to be drained (see Figure 5).

## 8 Resistance to chemicals

8.1 An assessment by the BBA indicates that the components of the system are suitable for use in contact with the chemicals likely to be found in rainwater.

8.2 An assessment of the suitability for use of the units on brownfield sites should be made only after

a suitable site investigation to determine the possibility for chemical attack. Particular care must be taken where acids and organic solvents are present at high concentrations. For further information contact the Certificate holder.

## 9 Maintenance

9.1 The customer is responsible for maintenance.

9.2 For soakaways to individual houses, the only necessary maintenance of the system is to keep gullies clear of debris such as leaves.

9.3 For large installations or where the receiving waters are environmentally sensitive, a system of regular inspections should be established to prevent siltation of the system which, if allowed to develop, would reduce effectiveness. They should also be inspected after every major storm event.

9.4 It is recommended that a silt trap is incorporated into the pipework at the inlet to the tank (see Figure 6). There must be a maintenance plan that ensures regular cleaning of the trap to ensure correct performance. Silt traps for use with this system are outside the scope of this Certificate.

9.5 For all flow control devices it is sensible to incorporate access (via a manhole or similar) to the location of the pipe entry, orifice or vortex control. This will enable easy removal of any blockage. The orifice itself may be protected by a debris screen.

9.6 Paved surface areas above an installation should be inspected at the same time to ensure the units continue to provide the required structural support.

Figure 6 Typical silt trap

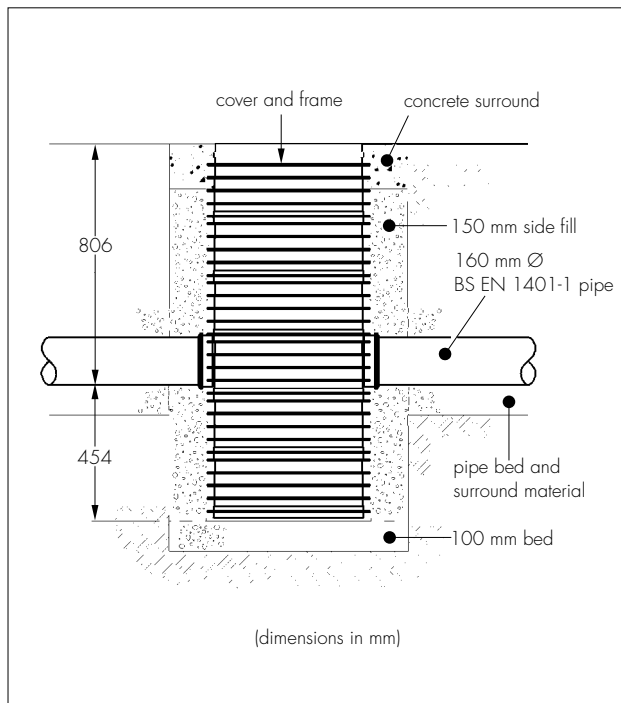

## 10 Durability



The structural properties of polypropylene used in the components of the system will deteriorate with time and should be taken into account at the design stage by the application of suitable safety factors. In the opinion of the BBA, the system, when used in accordance with this Certificate, will have a life in excess of 50 years.

## Installation

### 11 General

Polystorm 40 Tonne Units should be installed in accordance with the Certificate holder's installation instructions and relevant legislation. Special attention should be paid to temporary work requirements in excavations.

### 12 Procedure

12.1 The hole or trench is excavated to the required plan, dimension and level ensuring that the excavation will allow easy installation of connecting pipework. It must be ensured sufficient construction plant access is maintained for reinstating around the installed units. The base must be smooth and level without sharp drops or humps. Slopes must be cut to a safe angle or adequately supported and safe access must be provided to allow personnel to enter the excavation. Excavation should be carried out in accordance with BS 6031 : 1981, with particular attention paid to safety procedures.

12.2 It must be ensured that the ground-bearing capacity at formation level is adequate for the design loads.

12.3 The base must be inspected for soft spots in the formation — any present must be excavated and replaced with compacted granular fill material.

12.4 For an attenuation application a 100 mm thick, bedding layer of coarse sand is laid on the base of the excavation. The geotextile protection fleece is laid on base and sides if required. The geomembrane is laid over the sand bedding and up the sides of the excavation. Joints should be made in accordance with the manufacturer's recommendations with allowance made for connecting pipework or adaptors. The geomembrane and joints are inspected for damage.

12.5 For an infiltration application a 100 mm thick bedding of either coarse sand or Class 6H selected granular material [with 100% passing the 5 mm sieve, in accordance with the Manual of Contract Documents for Highway Works (MCHW) Volumes 1 and 2] is laid on the base of the excavation. The geotextile is laid over the bedding and up the sides of the excavation and joints formed in accordance with the manufacturer's recommendations, and allowance made for connecting pipework or adaptors.

12.6 The units are installed in accordance with the installation schedule for correct orientation. Wherever possible continuous vertical joints should be avoided. The units are arranged so that preformed sockets are in the correct alignment for inlet and outlet pipes. For single-layer applications, Polystorm clips only are used and for multi-layers Polystorm clips, shear connectors and brick bond connectors (when using brick bond arrangement) are used.

12.7 The geotextile or geomembrane encapsulation to base, sides and top of installation, including protective geotextile (where required) is completed. Geomembranes should be welded in accordance with manufacturer's recommendations. The geomembrane and/or geotextile is inspected for damage and all welds are tested as required.

12.8 Drainage connections are made to the installation using proprietary adaptors. Preformed socket positions for pipe connections must be located at the correct position for receiving pipework.

12.9 The installation is backfilled around the side of the encapsulated units to form a 100 mm layer of coarse sand or Class 6H selected granular material immediately adjacent to the units. Any remaining excavated areas around the units are backfilled with Class 6N or 6P selected granular material in accordance with MCHW Volumes 1 and 2. The backfill is compacted in 150 mm layers.

12.10 A coarse sand protection layer 100 mm thick should be placed over the top of the units that are wrapped in either a geotextile (infiltration system) or a geomembrane with protective geotextile (attenuation system). Backfilling is continued with:

- trafficked areas (eg restricted access car parks) — Type 1 or 2 sub-base material compacted in 150 mm layers in accordance with MCHW, Volumes 1 and 2. Compaction plant over the top of the system must not exceed 2300 kg per metre width. Where the units are to be installed beneath a paved area the pavement sub-base may form part of the backfill material provided minimum cover depths are maintained
- landscaped and non-trafficked areas — selected as-dug material with size of particles less than 40 mm within 300 mm of top of units. Above this level selected as-dug material may be used. Place backfill and compact in layers no greater than 300 mm. Compaction plant over top of system must not exceed 2300 kg per metre width.

12.11 The pavement construction or landscaping is completed over the units.

The following is a summary of the technical investigations carried out on Polystorm 40 Tonne Units.

### 13 Tests

Tests were carried out on the system to determine:

- long-term and short-term resistance to loading
- volumetric capacity

### 14 Investigations

14.1 The manufacturing process was examined including the method adopted for quality control, and details obtained on the quality and composition of the material used.

14.2 An assessment of the system was made in relation to:

- material properties
- design procedures.

14.3 A site visit was made to assess the practicability and ease of installation and connection.

## Bibliography

BS 6031 : 1981 *Code of practice for earthworks*

BS EN 752-4 : 1998 *Drain and sewer systems outside buildings — Hydraulic design and environmental considerations*

BS EN 1401-1 : 1998 *Plastics piping systems for non-pressure underground drainage and sewerage. Unplasticized poly(vinylchloride) (PVC-U) — Specifications for pipes, fittings and the system*

EN 965 : 1995 *Geotextiles and geotextile-related products — Determination of mass per unit area*

EN ISO 10319 : 1996 *Geotextiles — Wide-width tensile test*

EN ISO 11058 : 1999 *Geotextiles and geotextile-related products — Determination of water permeability characteristics normal to the plane, without load*

EN ISO 12236 : 1996 *Geotextiles and geotextile-related products — Static puncture test (CBR-test)*

EN ISO 12956 : 1999 *Geotextiles and geotextile-related products — Determination of the characteristic opening size*

ASTM D 1004 : 1994 *Test method for tear resistance (Graves tear) of plastic film and sheeting*

ASTM D 1505 : 2003 *Test method for density of plastics by the density-gradient technique*

ASTM D 3998 : 1981 (withdrawn 1990) *Test method for pendulum-impact resistance of extrusion plastometer extrudates*

ASTM D 4491 : 2004 *Test methods for water permeability of geotextiles by permittivity*

ASTM D 4833 : 2000 *Test method for index puncture resistance of geotextiles, geomembranes, and related products*

ASTM D 4885 : 2001 *Test method for determining performance strength of geomembranes by the wide strip tensile method*

ASTM D 5199 : 2001 *Test method for measuring the nominal thickness of geosynthetics*

ASTM D 5397 : 1999 *Standard Test Method for Evaluation of Stress Crack Resistance of Polyolefin Geomembranes Using Notched Constant Tensile Load Test*

Manual of Contract Documents for Highway Works, Volume 1 : *Specification for Highway Works* : May 2001 edition

Manual of Contract Documents for Highway Works, Volume 2 *Notes for Guidance on the Specification for Highway Works*, August 1998 (as amended)



On behalf of the British Board of Agrément

Date of issue: 1st March 2006

A handwritten signature in black ink, appearing to read 'G. A. Cooper'.

Chief Executive



# Electronic Copy

---

**British Board of Agrément**

P O Box No 195, Bucknalls Lane  
Garston, Watford, Herts WD25 9BA  
Fax: 01923 665301

©2006

e-mail: [mail@bba.star.co.uk](mailto:mail@bba.star.co.uk)  
website: [www.bbacerts.co.uk](http://www.bbacerts.co.uk)



For technical or additional information,  
contact the Certificate holder (see  
front page).  
For information about the Agrément  
Certificate, including validity and  
scope, tel: Hotline 01923 665400,  
or check the BBA website.